



Frost Code: 708-A

Universal Tank Type Liquid Soap Dispenser

UPC: 624622708009

Shipping Dimensions: 11.4cm H x 21.6cm W x 13.3cm D (4 1/2" H x 8 1/2" W x 5 1/4" D)

Shipping Weight: 1.1 kg (2.5 lbs)

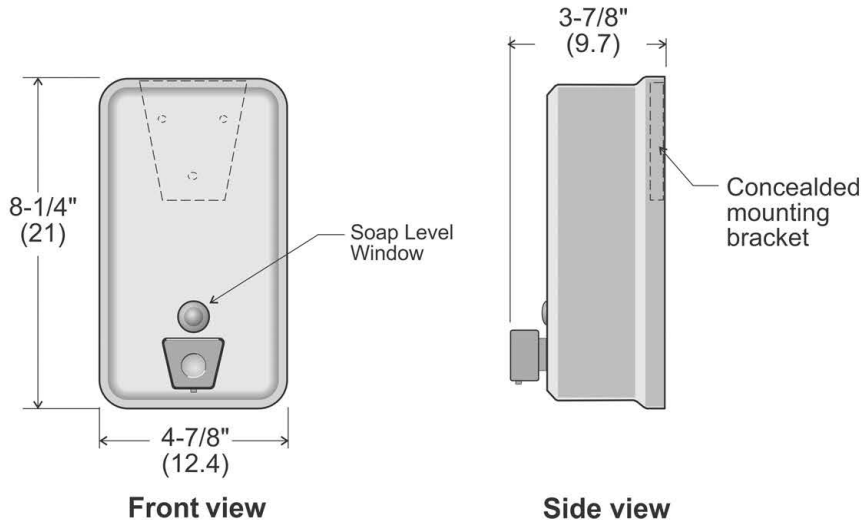

Specifications

Site Location:

Frost's 708-A universal vertically mounted liquid soap dispenser offers a durable and practical solution for high volume areas. Typically, the dispenser is used in schools/universities, restaurants, malls, office buildings, condominiums, fitness facilities, and recreation centres. This product was engineered to be easy to use and maintain without sacrificing the strength needed to last in busy environments.

Features:

- Straightforward design makes this product user friendly and also reduces the risk of product malfunction
- Non-proprietary dispenser which can lead to cost savings for end users and property managers
- Easily accessible refill at the top with keyed filler cap
- Lucite soap level indicator window
- Durable construction of 20 gauge type 304 stainless steel
- Concealed mounting screws

Dispensing:

Dispenses liquid soap at 10-20% solution as well as more viscous synthetic detergents, lotions, and antiseptic soaps. We do not recommend any soap types that have an ammonium based surfactant, ie. Ammonium Lauryl Sulfate, or chloride (Cl or NaCl) based solutions. Please discuss with your janitorial supplier as to which type of PH neutral liquid soaps would be appropriate for this product. Prolonged exposure to these harmful chemicals may lead to discolouration and/or corrosion of the stainless steel and are not covered under warranty.

Capacity:

- This dispenser has a 1.2 litre (40 US fl oz) capacity

Materials:

- Front: 20 gauge type 304 stainless steel, brushed finish
- Back: 20 gauge type 304 stainless steel, brushed finish
- Viewing Window: Lucite
- Nozzle: Plastic

Description and specifications applicable on date issued. Frost reserves the right to make improvements or changes without notice.

-Continued on Page 2-



Spécifications

Numéro du produit : 708-A

Solutions Hygiéniques Au Travail

DISTRIBUTEURS – RÉSERVOIRS DE SAVON

Code 708-A: Soupape tout usage, montage vertical

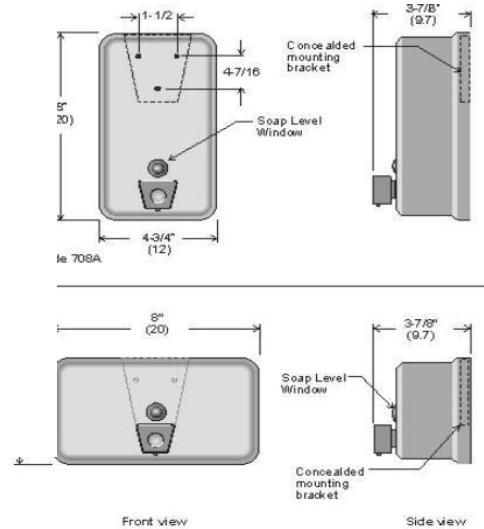

Caractéristiques:

Emplacement :

Le distributeur pour montage en surface peut se fixer sur tous types de parois et de matériaux.

Particularités :

Acier inoxydable de calibre 20, étiré et soudé. Remplissage par le dessus. Bouchon de remplissage à clé. Voyant indicateur de niveau en lucite. Vis de montage invisibles.

Types de savon

Les 708A et 710A s'utilisent avec du savon liquide, en solution de 10 à 20 %, ainsi qu'avec des détergents synthétiques, lotions et savons antiseptiques plus visqueux.

Capacité :

1,1 litre.

Installation :

Fixer la plaque de montage au mur, par ses trous à l'aide des quatre vis incluses. Glisser le distributeur sur la plaque et le fixer à l'aide de la vis traversant le couvercle-filtre du dessus.

Descriptions et spécifications applicables à la date d'émission. Frost se réserve le droit d'apporter des améliorations ou des changements sans préavis. 1 janvier 2016



Product Dimensions:

- 21.0cm H x 12.4cm W x 9.8cm D (8 ¼" H x 4 ⅞" W x 3 ⅞" D)

Product Weight:

- 0.9 kg (2 lbs)

Installation:

For unrestricted access, bottom of the unit to floor must be between 38.1cm to 121.9cm (15" to 48"). This dispenser comes with three standard Phillips style screws and a back plate. Mark mounting holes against the mounting surface using a pencil and level. Use a screwdriver or power drill to drill screws and back plate in the desired mounting surface and attach the dispenser. Please note that it is recommended that all installations be conducted by a qualified tradesperson. Please read and follow any additional installation guidelines provided with the products.

Maintenance:

Normal preventative maintenance and cleaning will keep Frost products functioning properly and may extend normal product life. We recommend that units be periodically rinsed out with warm water to prevent soap build up that may hinder the performance of the valve. Products should be wiped down with a damp soft cloth periodically. Approved stainless steel cleaner may be used to clean scuffs or fingerprints on stainless surfaces. Do not use harsh detergents or chemical cleaners. For stainless steel please do not spray with any product containing bleach, acids, or chlorides, which can be found in many cleaning products such as toilet bowl cleaners. Use of these cleaning solutions may cause discolouration and if used for prolonged periods of time they can eat away at points in the stainless steel. If discolouration occurs, the use of an approved stainless steel cleaner and a firmer scrub pad, such as a Scotch Brite Pad #7447, may remove the markings. Wipe away any debris from the area and gently rub with the pad. Then spray the area with a stainless steel cleaner/polish and rinse and dry. Always wipe with the grain direction for stainless steel products. If a cleaning agent has begun to eat away at the steel on a unit then the unit will likely need to be replaced. The stainless steel that Frost Products uses is of high quality and stainless steel is resistant to rust. However, discolouration that appears to be rust can be caused by cleaning solutions and soaps mentioned above. It is important to discontinue use of any cleaning agent or soap if discolouration begins to occur. Clean off the discolouration as quickly as possible to avoid any permanent damage to the unit. Maintenance staff should be taught how to recognize the signs that they are not using the appropriate cleaning products and how to correctly maintain stainless steel items.

Warranty:

If any product or part proves to be defective within 12 months from date of shipment from the factory it will be repaired or replaced without any charge including freight costs when authorized. Costs resulting from the installation or removal of defective products are not covered under this warranty. Discolouration to stainless steel parts resulting from exposure to harsh environmental and / or chemicals are not considered to be defects in workmanship or material and are not covered under warranty.